

TandoStone® Stacked Stone aLL-PRO CORNER® Installation Guide

System Components

TandoStone® Stacked Stone Panel

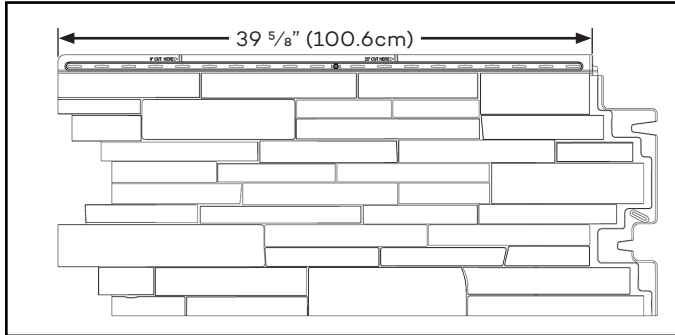

TandoStone® Universal Starter Strip

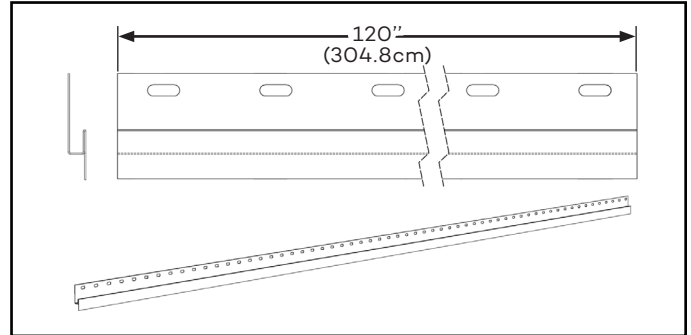

TandoStone® Stacked Stone aLL-Pro Corner® - "A"

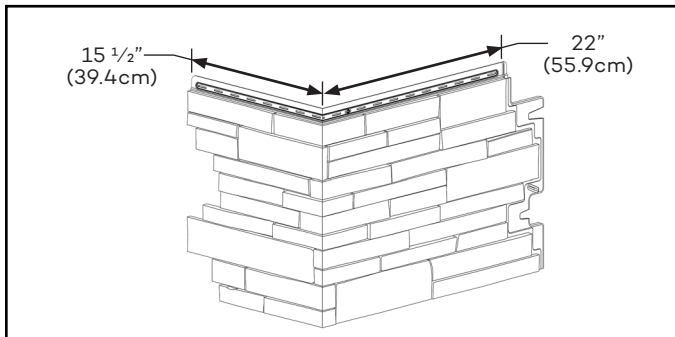

TandoStone® aLL-Pro Corner® - "B"

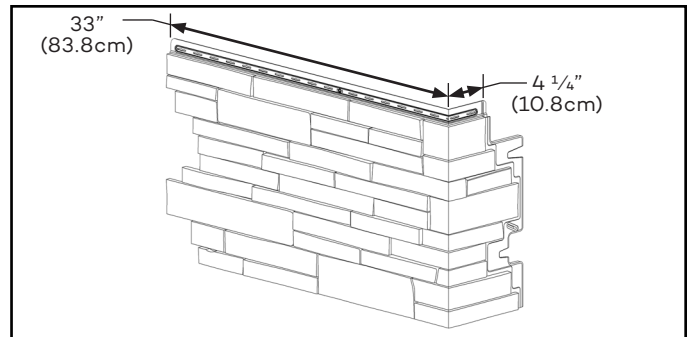

Kut Kit (1 tube of caulk & 13 crimp plates)

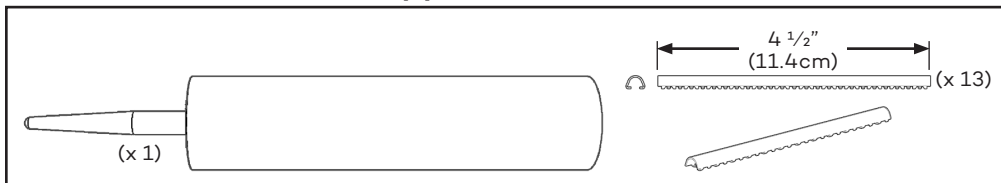

General information

- All TandoStone system components are manufactured by Derby Building Products in an ISO-certified facility and carry all major code listings (ICC, FBC, and CCMC).
- Variations in shade and color are designed into the TandoStone system to replicate authentic stone.
- TandoStone system components should be installed using proper building practices and in accordance with the local building codes.
- The TandoStone system is intended for use in a side-wall application only. It is the sole responsibility of the installer to ensure that it is fit for the intended use. Tando Composites accepts no liability for the improper installation of this product.
- It is best practice before beginning any project to have all applications reviewed by an architect, engineer, or local building official.
- If you have any questions or need further assistance, please visit our website at www.TandoComposites.com.

TandoStone® Stacked Stone aLL-Pro Corner® Installation Guide

Installation overview

- The TandoStone system is designed to be installed on a flat, smooth, solid wall (e.g., OSB or plywood) surface.
- The TandoStone system is designed as an exterior cladding, not a weather-resistant barrier. We recommend a weather-resistant barrier, such as a house wrap, be used in conjunction with the TandoStone system. As always, follow local building codes.
- When applying fixtures, always use a solid support or specifically designed mounting blocks. Follow the mounting block manufacturer's installation instructions. Fixtures should not be installed directly to the aLL-Pro Corner or TandoStone.
- For best results use non-corrosive fasteners (ex: galvanized or stainless steel).
- Begin the installation at the lowest point of the side wall, working from left to right installing one row at a time.
- There is a sticker containing a production lot number (REL) on each box and on the back of each panel. Keep the number (ex: REL-123456) for future reference.

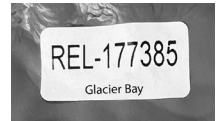

Storage and handling

- Each aLL-Pro Corner box contains 4 corners - 2 "A" and 2 "B" corners.
- A box of TandoStone Stacked Stone contains 10 panels.
- Boxes of aLL-Pro Corner and TandoStone must be kept dry.
- Store boxes upright according to the directions on the box. Do not store corners or panels lying flat.
- TandoStone and the aLL-Pro Corners are engineered with innovative, high-tech coatings. When handling, use care not to gouge or scrape the exposed (front) product surface.



Tools required

- In addition to the standard tools that would be needed to install TandoStone (i.e., measuring tape, hammer, square, drill, hammer, saw, etc.), a caulk gun and linesman crimpers and/or pliers will be necessary to install the aLL-Pro Corner.



Standard tools



Linesman crimpers, duct crimpers, or pliers

Wall preparation

- The TandoStone system is to be installed over a smooth, flat surface.
- We recommend a weather-resistant barrier, such as a house wrap, be used in conjunction with the TandoStone system. As always, follow local building codes.
- Unlike stone or stone veneer, the TandoStone system is designed to allow proper drainage without the need for supplemental rain screens.

Cutting

- For best results use carbide-tipped blades with 8 teeth or more per inch.
- Panels should be cut face up.
- Snips can be used, but cutting with snips may be difficult. However, snips should not be used to cut panels to fabricate a Kut Panel or Kut Panel XL.

TandoStone® Stacked Stone aLL-Pro Corner® Installation Guide

Starter strip installation

- Starter strips must be installed at the base of every wall.
- **When installing the aLL-Pro Corner, ensure the starter strips are extended to the end of each wall.**
- **Ensure the Starter Strips are level.**
- If there is a solid surface (drive way, concrete, deck, etc.) at bottom of the siding, install the top of the starter strip at 2 1/8" (5.4cm) above it in order to leave a 1/4" (0.6cm) clearance underneath.
- If there is no hard surface, mount starter strips flush with the base of the wall.
- Fasten starter strip using standard roofing nails.
- Fasteners should be flush to the surface and no more than 8" (20.3cm) apart.
- Continue installing across the wall area by placing the next starter strip in line with the previous one.
- Be sure to align starter strips on adjacent walls.

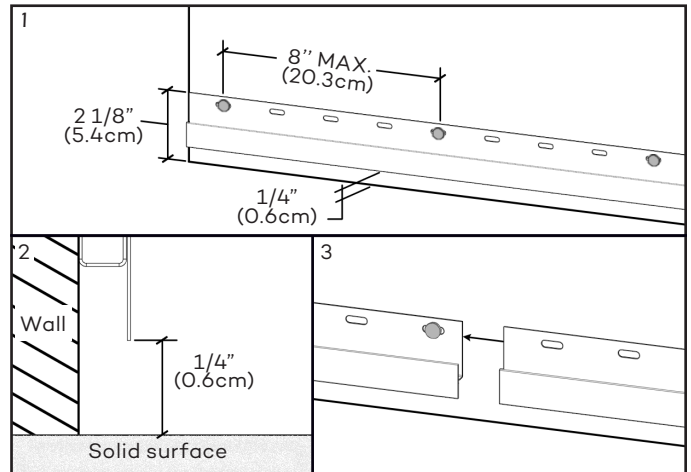

Fasteners

- For most installations, use 1 1/2" roofing nails.
- For best results use galvanized or stainless steel fasteners.
- Fasteners should penetrate into solid substrate (e.g., OSB or plywood) a minimum of 7/16" (1.1cm) thickness.
- If fastening through insulation or foam, increase the length of the fastener to account for the additional thickness of the foam. Ensure the fasteners penetrate the 7/16" solid surface.
- Always leave a gap of 1/16" (0.2cm) between the nailing channel and the fastener head.

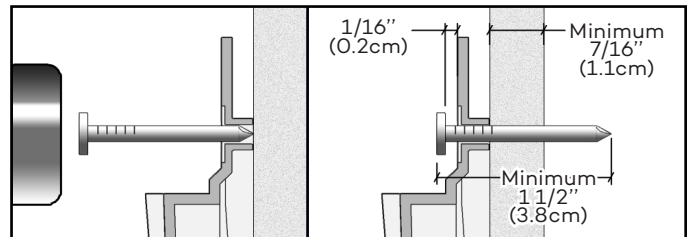

Fastening the aLL-Pro Corner

- The first two fasteners should be installed in the nailing slots closest to the corner and nailed flush.
- Next, install one fastener in the last nailing slot on both ends of the aLL-Pro Corner leaving a 1/16" (0.2cm) clearance between the nailing channel and the fastener head.
- Continue installing fasteners across the nailing flange, no more than 8" apart.
- Do not use the manufactured center nail hole on the aLL-Pro Corner.
- Last, install one fastener in lateral nailing slot.
- Up to 8 fasteners will be used in an aLL-Pro Corner installation (7 fasteners in the nailing flange and 1 in the lateral nailing slot).

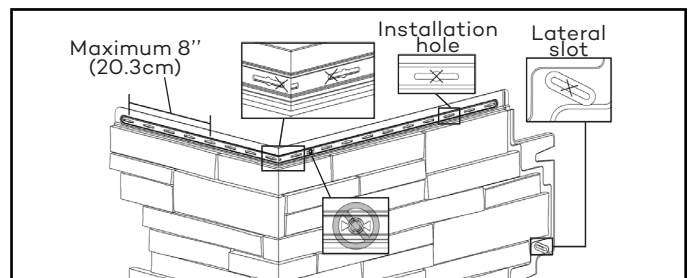

NOTE: If TandoStone and the aLL-Pro Corner are installed on a wall with furring strips, please visit our website at www.TandoComposites.com and refer to the additional information for installing over masonry, stucco or concrete masonry units.

TandoStone® Stacked Stone aLL-Pro Corner® Installation Guide

Installation line/notch

- TandoStone panels and aLL-Pro Corners have a installation line/notch in the upper right corner.
- In most installations (outdoor temperature above 32°F/0°C), position the TandoStone panel so its upper left edge meets the installation line/notch on the right side of the aLL-Pro Corner's nailing flange.
- In cold weather installations (below 32°F/0°C), position the TandoStone panel 1/16" (0.2cm) to the right of the installation line/notch on the aLL-Pro Corner.

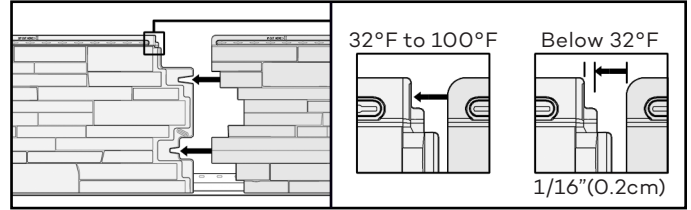

Installing the TandoStone® Stacked Stone using the aLL-Pro Corner

- NOTES:**
- TandoStone system is always installed left to right, bottom to top.
 - There are 2 models of the aLL-Pro Corner - "A" and "B".
 - Start first course with "A" corners on both left and right end of the wall.
 - Each additional course will alternate the corner type. For example, row #2 will use "B" corners, row #3 will use "A" corners, row #4 "B" corners and so on.

There are two common installation scenarios:

1. A wall that includes a door or window. This will apply on many projects.
2. A wall with a continuous run without a door or window.

1- Installation on a wall with a door or window

- Fasten an "A" aLL-Pro Corner onto the starter strips at the left side (Figure 1).
- Next, place and fasten full length of TandoStone panels on the starter strip, from left to right toward the door/window.
- Repeat this step until the remaining distance to the door/window will not accommodate a full panel.
- Measure the opening between door/window to the installation line/notch of the last panel and cut a panel that is approximately 1/4" (0.6cm) shorter.
- Install and fasten this shorter panel to complete the left side of the door of the first course (Figure 2).
- On the right side of the door, temporarily tack the aLL-Pro Corner "A" at the end of the wall for easy removal later (Figure 3).
- Then, dry fit full length panels toward the left until no more full panel can fit next to the door/window.
- Measure the opening between door/window to the nailing flange left edge of last panel and cut a panel that is approximately 1/8" (0.3cm) shorter (Figure 4).

Figure 1

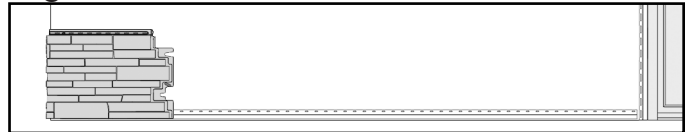

Figure 2

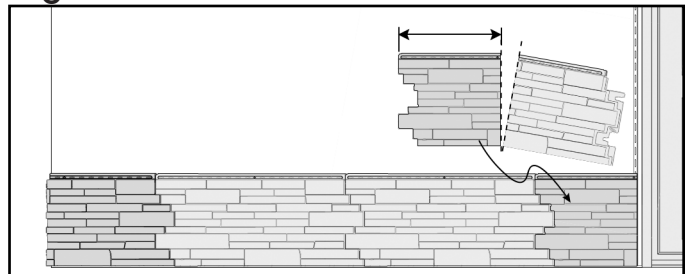

Figure 3

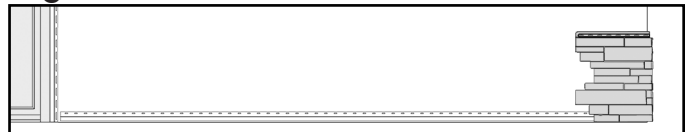
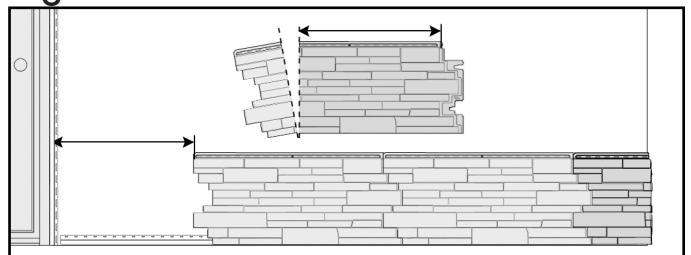

Figure 4



TandoStone® Stacked Stone aLL-Pro Corner® Installation Guide

1- Installation on a wall with a door or window (continuation)

- Remove all dry fit panels and the aLL-Pro corner at right end, then install and fasten this shorter panel with the cut edge 1/8”(0.3cm) away from the door/window (Figure 5).
- Reinstall and securely fasten all TandoStone panels from left to right as well as the aLL-Pro corner “A” onto the right end of wall (Figure 6).
- Repeat all these steps on second course using the aLL-Pro Corners “B”.
- Remember that each additional row will use alternating corners. For example, row #3 will use “A” corners, row #4 “B” corners and so on (Figure 7).

Figure 5

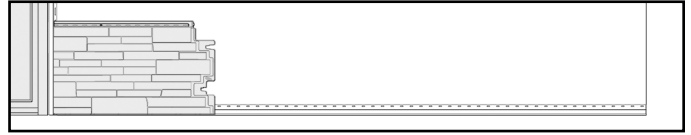

Figure 6

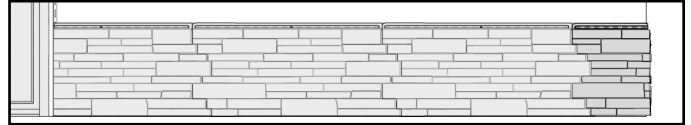
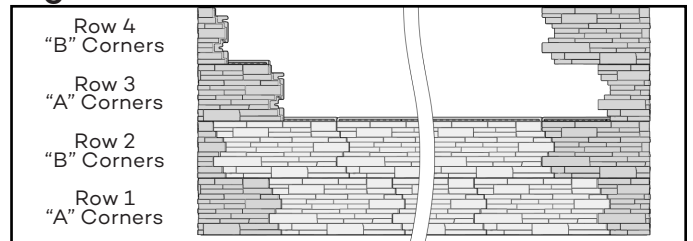

Figure 7



2- Installation on a wall without a door or window

- Fasten the “A” aLL-Pro Corner on left end of the wall and temporarily tack an “A” corner on the right end (Figure 8).
- Next, measure the opening between the two corners from the installation line/notch on the left corner to the nailing flange left edge of the corner on the right.
- Use 40”(101.6cm) as the approximate width of a full panel to calculate how many full length panels will fit in this opening (Figure 9).
- Once the number of full 40”(101.6cm) panels is determined, the remaining space will be the approximate size of the Kut panel or Kut panel XL that is required.
- If that remaining space is 12”(30.5cm) or more, start installing and fastening the full panels from left to right until the place where the Kut panel will be installed (Figure 10).
- If that remaining space is less than 12”(30.5cm), remove one full length panel from the quantity calculated and start installing and fastening them from left to right until the place where the Kut panel XL will be installed (Figure 11).

Figure 8



Figure 9

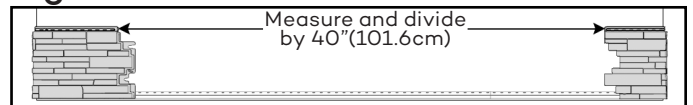

Figure 10

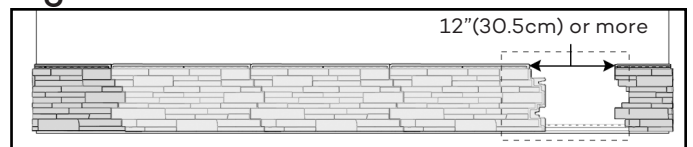
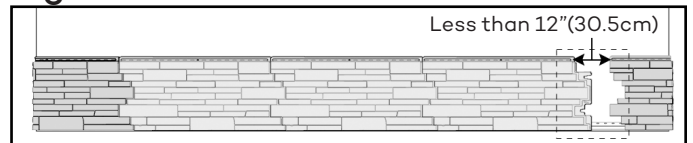

Figure 11



TandoStone® Stacked Stone aLL-Pro Corner® Installation Guide

2- Installation on a wall without a door or window (continuation)

- Before installing the Kut panel or Kut panel XL, remove the temporarily tack corner on right.
- Then, once the Kut panel or Kut panel XL is fabricated (see page 7 for details) place it and securely fasten it on wall (Figure 12).
Fastening the Kut panel or Kut Panel XL (Figure 13):
 - Nail the Kut Panel or Kut Panel XL in place with fasteners on both sides of the Kut Panel seam - as close as possible to the seam inside the nailing slot.
 - Then, fasten into the center of nailing slot at far left end and far right end of the Kut Panel.
 - Proceed to fasten at least every 8" (20.3cm).
 - Do not place a fastener into any manufactured center nail hole of a Kut Panel.
- Finally, complete the row by reinstalling and fastening the aLL-Pro corner in place according to the proper fastening guidelines (Figure 14).
- Repeat all these steps for each subsequent course and remember to alternate the "A" and "B" aLL-Pro corners on each course.

Figure 12

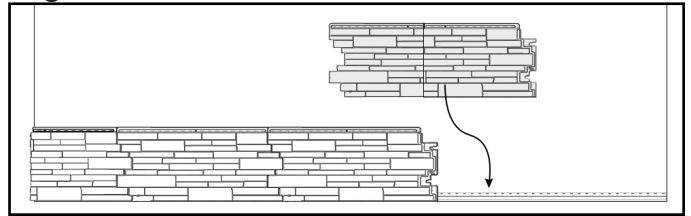

Figure 13

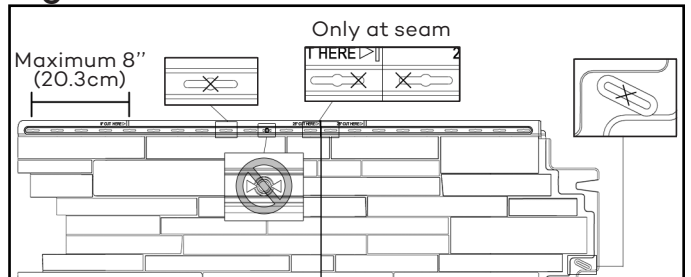
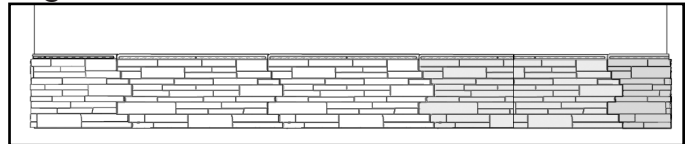

Figure 14



TandoStone® Stacked Stone aLL-Pro Corner® Installation Guide

Making a Kut Panel or Kut Panel XL

- There are (4) easy steps in making a Kut Panel or Kut Panel XL: **Measure, Cut, Crimp, and Caulk.**
- **IMPORTANT – Always us a Kut Kit to fabricate a Kut Panel or Kut Panel XL. Each Kut Kit can make (4) Kut Panel, or (4) Kut Panel XL.**

1-MEASURE:

- Measure precisely the opening where the Kut Panel will be installed. This measurement is the exact size of Kut Panel required.
- Measure from the installation line/notch on the left panel or corner to the edge of the nailing flange on the right.

Figure 15

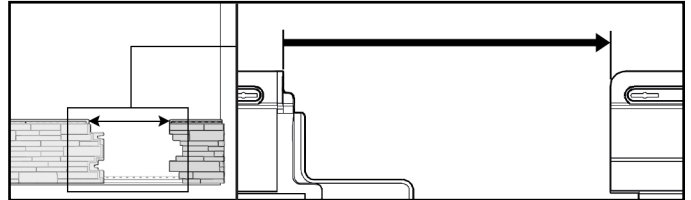

2-CUT:

- Start by cutting the left section of the Kut Panel or Kut panel XL.
 - From one full panel, cut through the 9" mark for a Kut Panel or through the 25" mark for a Kut Panel XL (Figure 16).
- Then, cut the right hand section of the Kut Panel or Kut Panel XL. The right section should be the dimension of the opening minus the dimension of the left section. Measure from the installation line/notch on the right, mark and cut the second piece of the Kut Panel or Kut Panel XL (Figure 17).
- Once the two pieces for the Kut Panel are created, double check the measurements to make sure the length of the Kut Panel matches the measurement of the opening to fill (Figure 18).

Figure 16

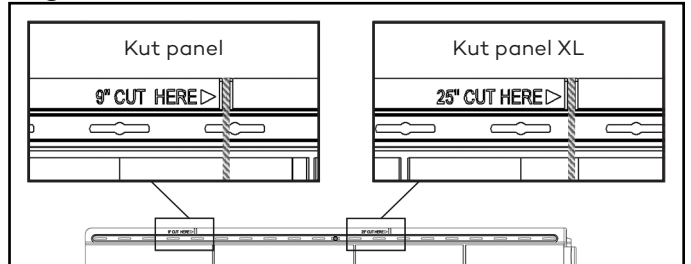

Figure 17

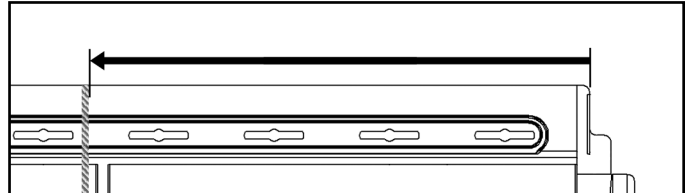
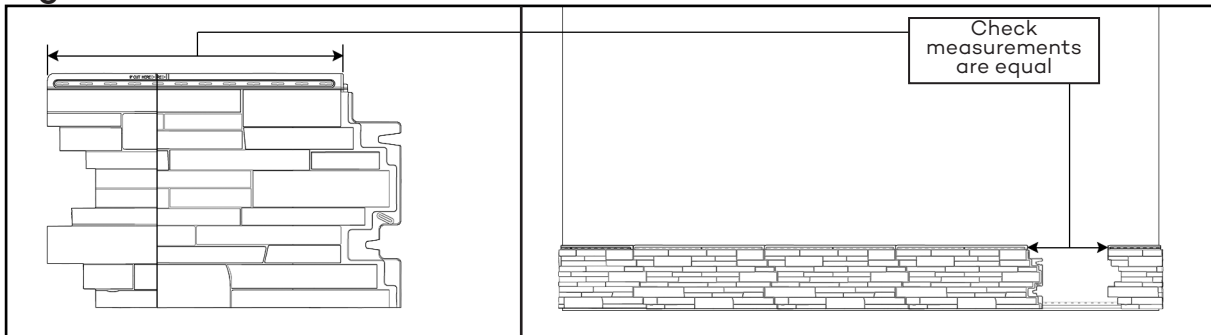

Figure 18



TandoStone® Stacked Stone aLL-Pro Corner® Installation Guide

Making a Kut Panel or Kut Panel XL (continuation)

3-CRIMP:

- Place the two cut pieces together, face down, on a flat surface with horizontal ribs aligned and eliminate any gap between cut panel pieces.
- Place one (1) crimp plate at each of the 3 horizontal panel ribs.
- Ensure crimp plates lie flush over ribs. If there is a spine impeding the crimp plate lying flat, trim portion of the spine to enable crimp plates to lie flat.
- Using crimper tool or pliers, crimp/squeeze the crimp plates tightly to secure panels together.
- Ensure the teeth of the crimp plates seat securely into the horizontal ribs.

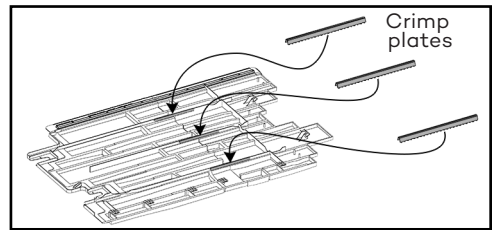

4-CAULK:

- Using the color-matched caulk supplied in Kut Kit, place a bead of caulk 3/8"(1cm) wide over the seam and over the crimp plates to fill any spaces/ openings.
- Make sure to apply caulking from the back with the tube nearly perpendicular to the panel.
- The assembly can be installed on the wall immediately.

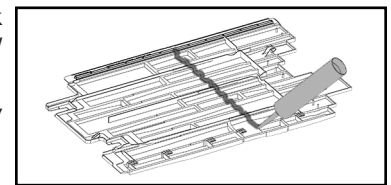

SPECIAL NOTES

- A Kut Panel should not be fabricated shorter than 12"(30.5cm).
- A Kut Panel XL should not be fabricated longer than 52"(132.1cm).